

TENSION DEVICE

EACH OF THE 36 WIRE CAN BE INDIVIDUALLY ADJUSTED ACCORDING TO THE SIZE. THESE WIRES SHOULD BE CUT OFF 6 INCHES IN FRONT OF THE TENSION DEVICE.

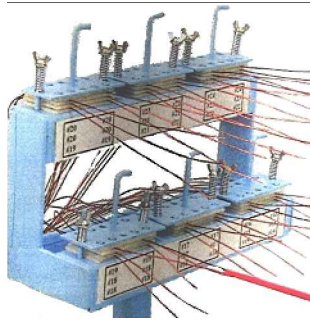

WIRES WILL LIE SIDE BY SIDE, ELIMINATING CROSSES IN COILS AND ALLOWING COILS TO GO IN SLOTS OF MOTOR MUCH EASIER.

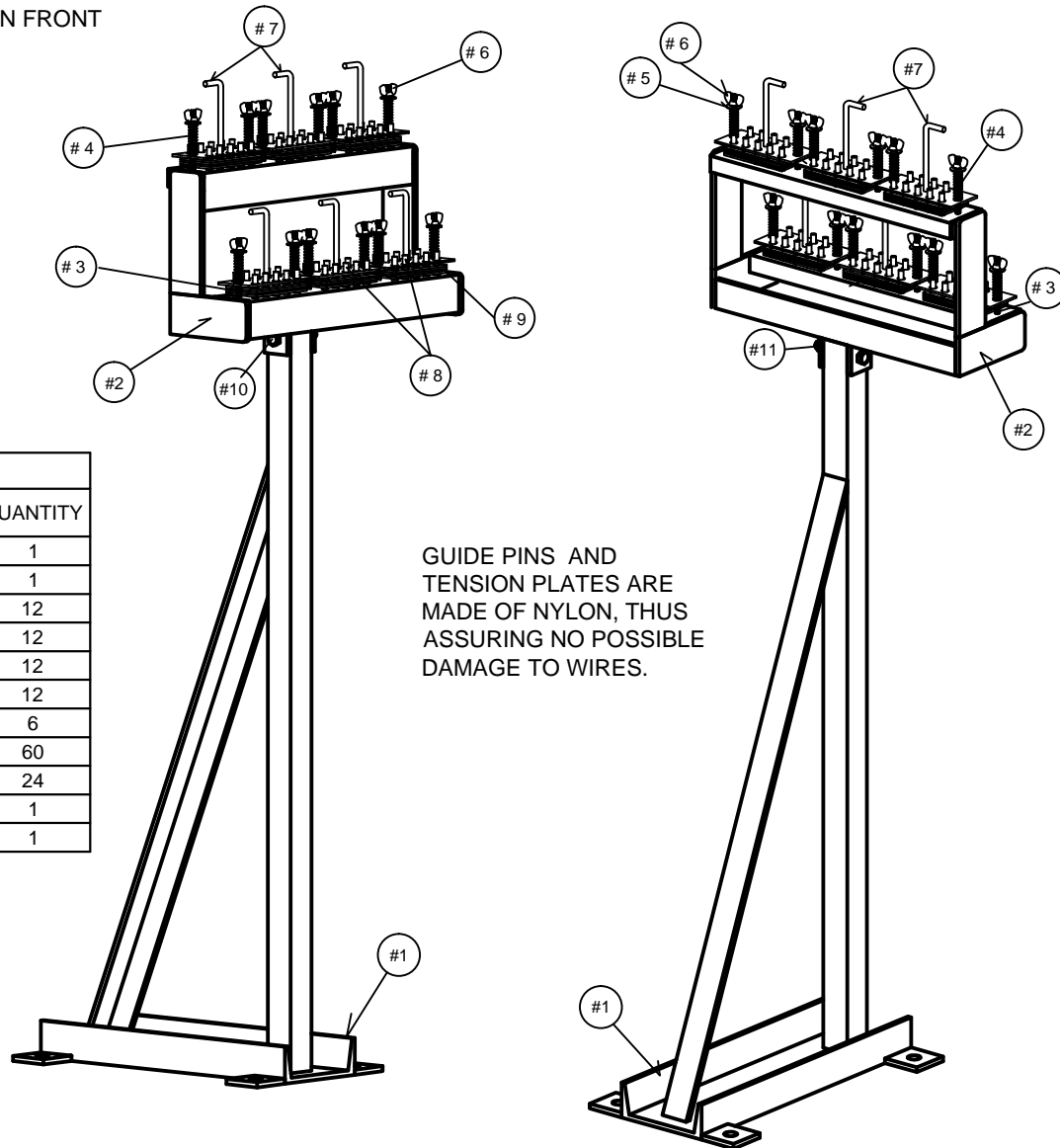

GUIDE PINS AND TENSION PLATES ARE MADE OF NYLON, THUS ASSURING NO POSSIBLE DAMAGE TO WIRES.

PART LIST SW 300-T

ITEM	PART#	DESCRIPTION	QUANTITY
1	SW301	Base Assembly	1
2	SW302	Main Tensioner Assembly	1
3	SW303	Screws	12
4	SW304	Compression Springs	12
5	SW305	Washers	12
6	SW306	Wing Nuts	12
7	SW307	Quick Release Plate	6
8	SW308	Guide Pins	60
9	SW309	Tension Plates	24
10	N/A	Cap Screw	1
11	N/A	Hex Nut	1

MODEL: SW-300-T